

METALIA[®]

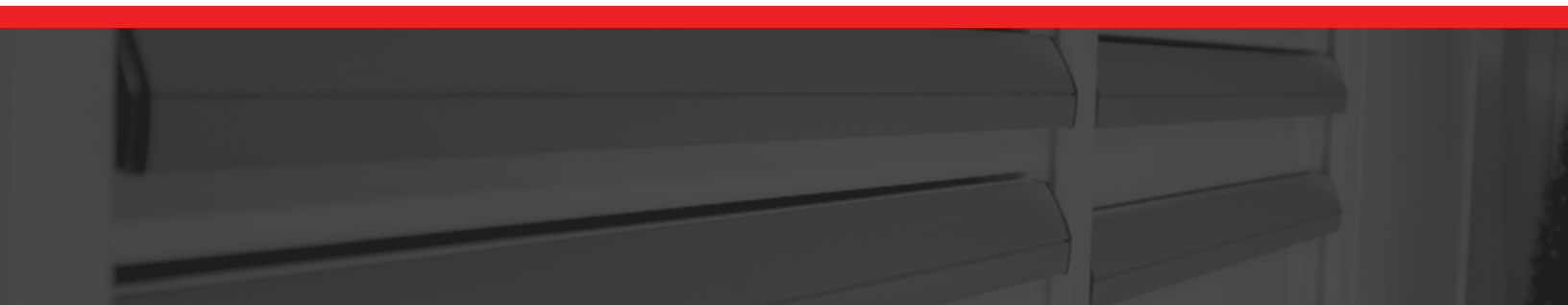

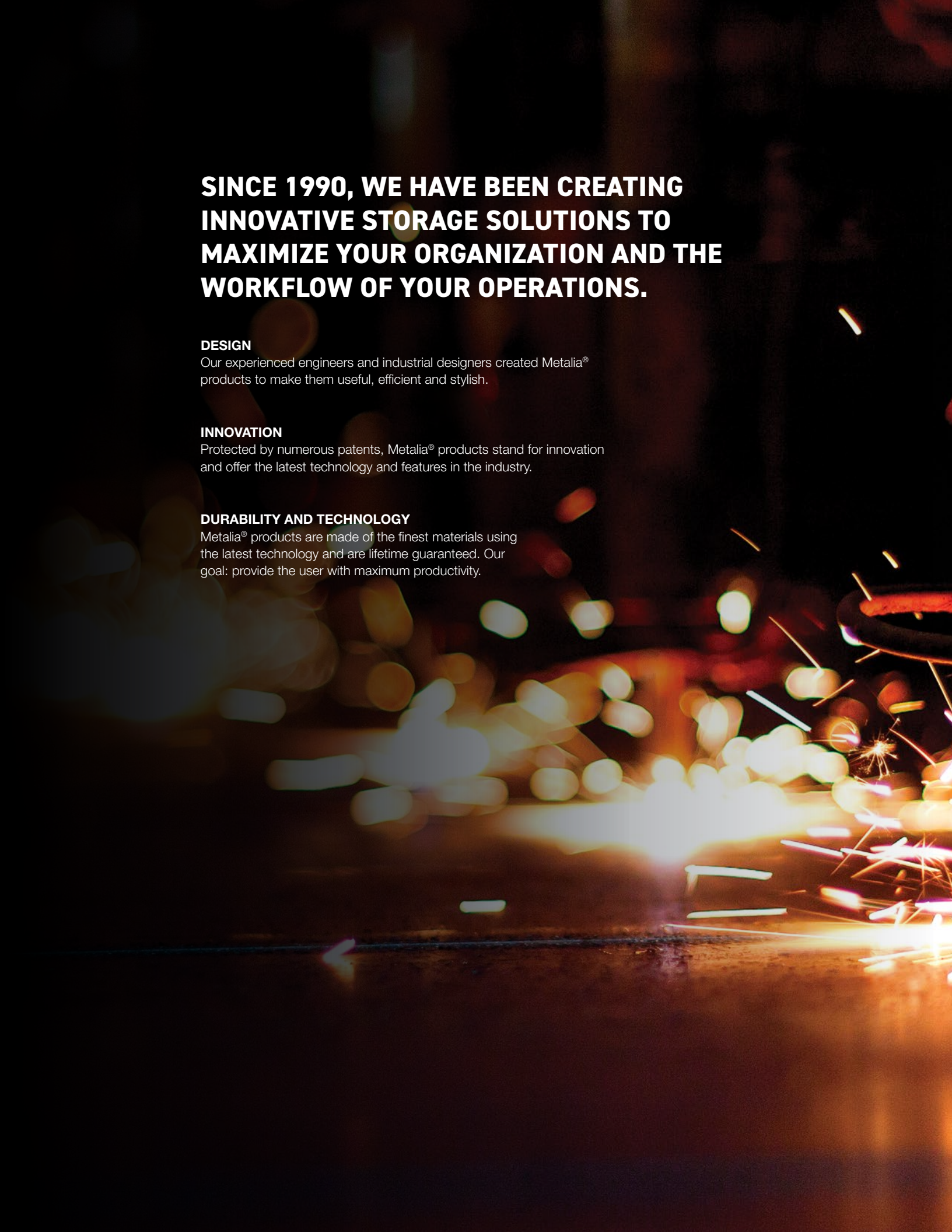

**SINCE 1990, WE HAVE BEEN CREATING
INNOVATIVE STORAGE SOLUTIONS TO
MAXIMIZE YOUR ORGANIZATION AND THE
WORKFLOW OF YOUR OPERATIONS.**

DESIGN

Our experienced engineers and industrial designers created Metalia® products to make them useful, efficient and stylish.

INNOVATION

Protected by numerous patents, Metalia® products stand for innovation and offer the latest technology and features in the industry.

DURABILITY AND TECHNOLOGY

Metalia® products are made of the finest materials using the latest technology and are lifetime guaranteed. Our goal: provide the user with maximum productivity.



TABLE OF CONTENTS

MS Series	4
Maximize your profit per square foot	6
Available dimensions	7
Optimized space, optimized output	8
Modular cabinet models	13
Mobile cabinet models	16
Build your own modular cabinet	17
Modular drawer models	18
Configure your own modular drawers	19
Drawer dimensions	20
Partitions and dividers	21
Modular cabinet and modular drawer accessories	22
WRS Series	24
Supercharge your service department workflow	26
Workstation models	30
Available colors	41
Build your own workstation	42





MS
SERIES

MODULAR CABINETS & MODULAR DRAWERS



OPTIMIZED SPACE. OPTIMIZED OUTPUT.

MAXIMIZE YOUR PROFIT PER SQUARE FOOT WITH MS SERIES

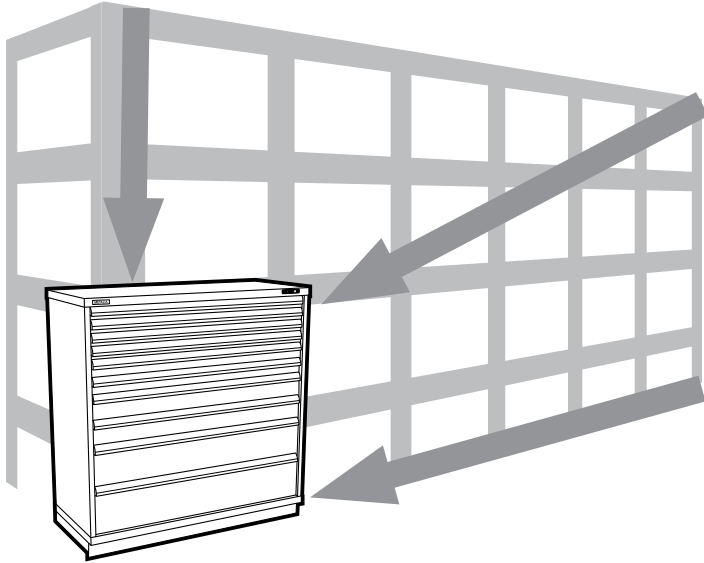

TRANSFORM EVERY SQUARE FOOT INTO PROFITS

Store more in our modular cabinets and transform up to **70% of the space used by regular shelves into profit making floor space.**

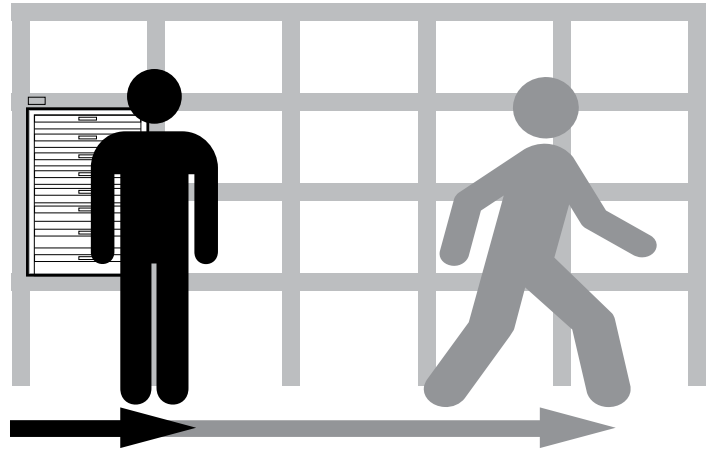

WALK LESS, SAVE MORE

Keep the most popular items at hand, **increase your productivity and your picking rate by 25%.**

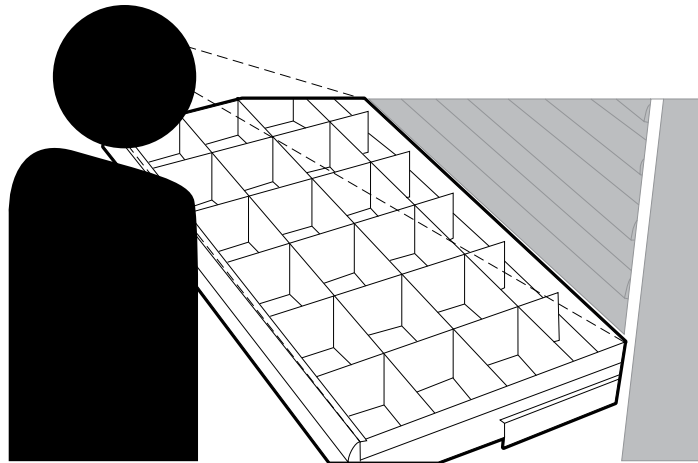

KEEP AN EYE ON YOUR INVENTORY

See your whole inventory **at a glance**, limit waste and unnecessary purchases.

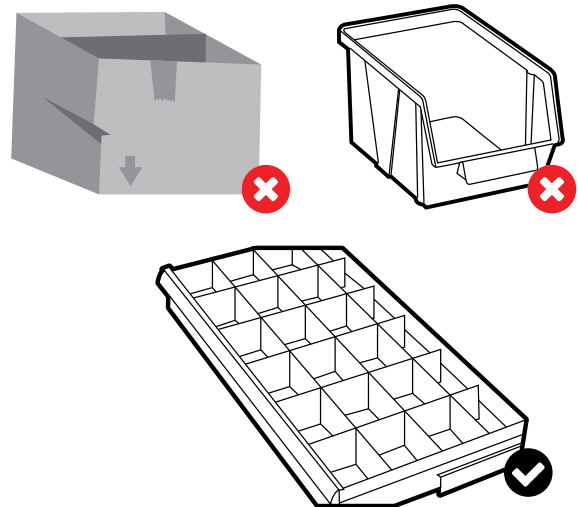

INVEST IN ADAPTABLE AND DURABLE STORAGE

Outperforming other organization methods, our partitions and dividers are **indestructible, infinitely adjustable and adaptable to your evolving needs.**



AVAILABLE DIMENSIONS

MODULAR CABINETS

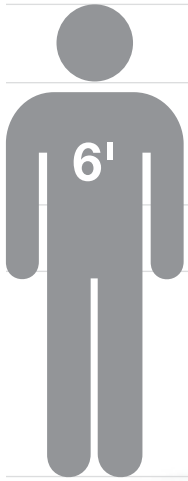

MODULAR DRAWERS

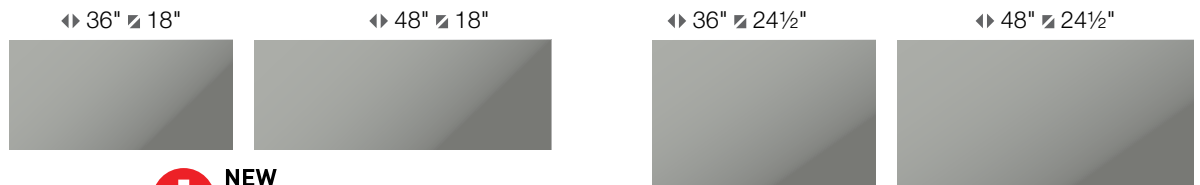
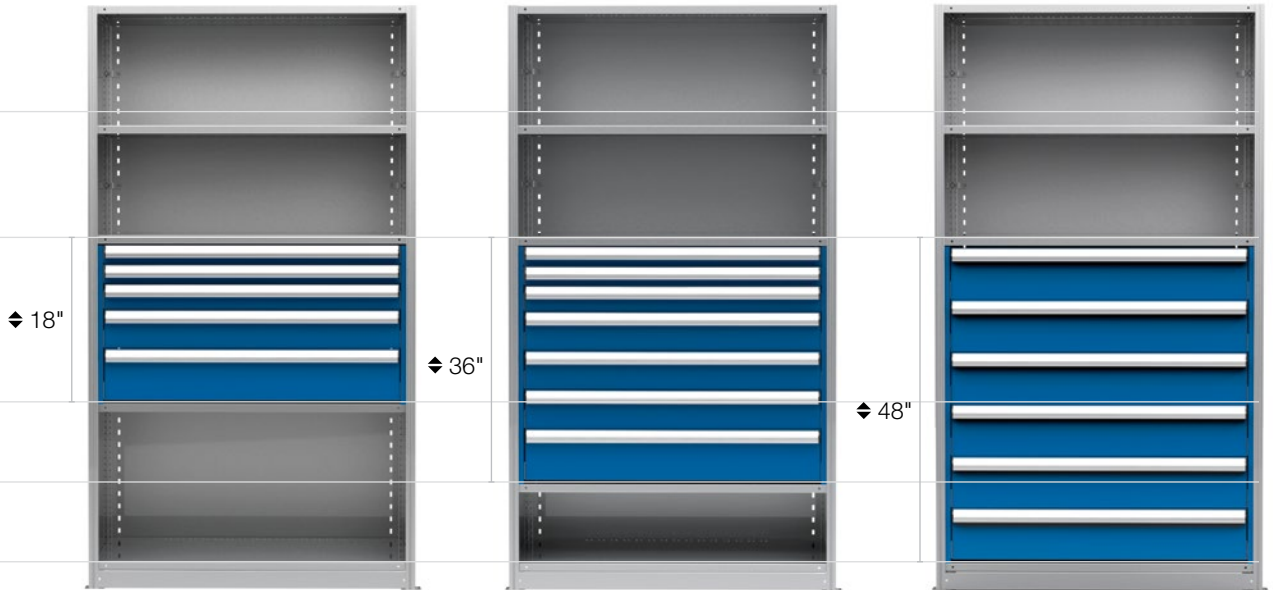
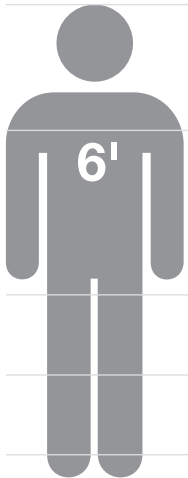

NEW PRODUCT!
PLEASE INQUIRE FOR LEAD TIME.



MODULAR CABINETS & MODULAR DRAWERS

OPTIMIZED SPACE. OPTIMIZED OUTPUT.

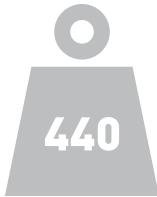

440 LB CAPACITY PER DRAWER

10% more than industry standard.

What's in it for you?

- Store more in less space.
- Eliminates deformation of the drawer.
- Less strain on the unit, improved lifetime.

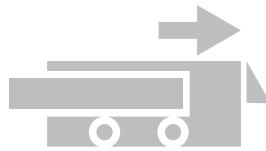

SWISS-MADE SLIDING SYSTEM ON DELRIN® WITH SAFETY LOCK

NASA sourced material is used to create the world's best sliding system.

What's in it for you?

- Self-lubricating, maintenance free and keeps its properties in extreme temperatures.
- Ensures maximum reliability, precision and smoothness for the lifetime of the unit.
- Safety Lock system prevents drawers from accidentally falling out of the cabinet.

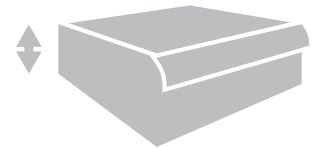

FULL HEIGHT DRAWER SIDEWALLS

Every cubic inch at your service.

What's in it for you?

- Prevents items from mixing or falling off drawer's sides.
- Maximize your investment by using every square inch available.
- Available in every drawer height.



INTEGRATED FORKLIFT BASE

Mobility... simplified.

What's in it for you?

- Provides safer and easier moving of the unit.
- A front kick-plate preserves the clean look of the cabinet.

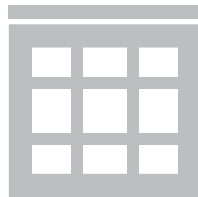

PARTITIONS AND DIVIDERS

Organized to perform better.

What's in it for you?

- Organize tools and parts of all sizes efficiently.
- A modular system, adaptable to your evolving storage needs.
- Ultimate durability, superior to any other storage method.



100% OPENING

Easy access and control over what matters most to you.

What's in it for you?

- Use the full depth of the drawer.
- Easy access to the longest tools and the most cumbersome parts.
- Full visual inspection of your inventory minimizing waste and unnecessary purchases.



METALIA® LIFETIME WARRANTY

Store your worries away.

What's in it for you?

- Ensures high performance through the whole life cycle of the unit, limiting downtime.
- Peace of mind: All Metalia® products carry a Lifetime Warranty.

NEW TO
MS
SERIES

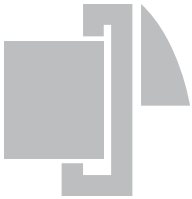

ROLLED-EDGES DRAWER FACE

Durability on the frontline.

What's in it for you?

- 14 gauge steel for industry-leading stiffness and rigidity you can feel on every pull.
- Keeps drawer from bending under heavy load.
- Prevents wear and extends lifetime.



DIGITAL LOCKING SYSTEM*

Better control, easier management.

What's in it for you?

- Simplified access control for managers with Master Code.
- Eliminates the need to track keys (loss, turnover).
- Millions of possibilities with an 8 digit code.



LED DRAWER LIGHTING*

Focus on your productivity.

What's in it for you?

- Find what you are looking for faster, without relying on surrounding lighting.
- Effective in all drawers.

NEW TO
MS
SERIES



ERGONOMIC DRAWER HANDLE WITH PATENTED DESIGN

Quality you can feel.

What's in it for you?

- Eliminate the risk of snagging with this unique patented handle flush with housing.
- Robust aluminum construction, modern design, improved looks.
- Available with a heavy-duty lock-in mechanism*.



NEW PRODUCT!
PLEASE INQUIRE FOR LEAD TIME.



"ONE DRAWER AT A TIME" SYSTEM*

Safety is the #1 priority.

What's in it for you?

- Eliminates the risk of injuries by keeping cabinet from tipping.
- A must-have for mobile cabinets and toolboxes.



UNIQUE POWDER COATING

Great look, durable, amazing protection.

What's in it for you?

- The best protection against scratches, abrasion and corrosion.
- Ensures a top notch look for the lifetime of the unit.

* Available as an option. Please inquire for lead time.

OPTIMIZED SPACE. OPTIMIZED OUTPUT.



12 REASONS TO CHOOSE A MS SERIES MODULAR CABINET



- 1 440 lb capacity per drawer**
10% more than industry standard.



- 7 Integrated forklift base**
Mobility... simplified.



- 2 Swiss-made sliding system on Delrin® with Safety Lock.**
NASA sourced material is used to create the world's best sliding system.



- 8 Partitions and dividers**
Organized to perform better.



- 3 Full height drawer sidewalls**
Every cubic inch at your service.



- 9 100% opening**
Easy access and control over what matters most to you.



- 4 Rolled-edges drawer face**
Durability on the frontline.



- 10 Ergonomic drawer handle with patented design and lock-in mechanism***
Quality you can feel.



- 5 Digital locking system***
Better control, easier management.



- 11 "One drawer at a time" system***
Safety is the #1 priority.



- 6 LED drawer lighting***
Focus on your productivity.



- 12 Unique powder coating**
Great look, durable, amazing protection.

* Available as an option. Please inquire for lead time.

models

MODULAR CABINETS

↔ 30" X ↗ 24½" 36" X 24½" 48" X 24½" 60" X 24½"

MODULAR CABINET MODELS

All cabinet models include forklift base with front cover, partitions and dividers. See all accessories on pages 22 & 23.

To complete your order: **500DD32-0501F-** -

Type of lock:
D: Digital lock
K: Key lock

"One-drawer-at-a-time" system:
0: Without
1: With

Color code:
 See all colors on page 41.

LEGEND



Width



Depth



Height



of drawers



of compartments



500DD32-0201F- -
 ◆ 32½" 2 12



500DD32-0501F- -
 ◆ 32½" 5 110



500DD32-0502F- -
 ◆ 32½" 5 106



500DD32-0601F- -
 ◆ 32½" 6 135



500DD32-0602F- -
 ◆ 32½" 6 150



500DD32-0701F- -
 ◆ 32½" 7 175



500DD40-0401F- -
 ◆ 40¼" 4 47



500DD40-0601F- -
 ◆ 40¼" 6 135



500DD40-0801F- -
 ◆ 40¼" 8 170

STANDARD COMPARTMENTS PER DRAWER

Drawer dimensions					Configurations for Modular drawers only.	
	30" X 24½"	36" X 24½"	48" X 24½"	60" X 24½"	36" X 18"	48" x 18"
3"	25 (0420)	24 (0518)	24 (0518)	32 (0724)	24 (0518)	36 (0530)
4"	25 (0420)	24 (0518)	24 (0518)	32 (0724)	24 (0518)	36 (0530)
5"	25 (0420)	24 (0518)	24 (0518)	32 (0724)	24 (0518)	36 (0530)
6"	25 (0420)	24 (0518)	24 (0518)	32 (0724)	24 (0518)	24 (0518)
8"	10 (0405)	6 (0203)	12 (0506)	12 (0506)	8 (0304)	12 (0506)
10" to 14"	6 (0203)	6 (0203)	12 (0506)	12 (0506)	6 (0203)	5 (0400)

See page 21 for all available layouts.



500GD32-0401F- -
 ◆ 32½" 🗑️ 4 🗑️ 78



500GD32-0501F- -
 ◆ 32½" 🗑️ 5 🗑️ 102



500GD32-0502F- -
 ◆ 32½" 🗑️ 5 🗑️ 120



500GD40-0501F- -
 ◆ 40¼" 🗑️ 5 🗑️ 84



500GD40-0701F- -
 ◆ 40¼" 🗑️ 7 🗑️ 150



500GD40-0901F- -
 ◆ 40¼" 🗑️ 9 🗑️ 216



500GD60-0701F- -
 ◆ 60" 🗑️ 7 🗑️ 60



500GD60-0901F- -
 ◆ 60" 🗑️ 9 🗑️ 180



500GD60-1301F- -
 ◆ 60" 🗑️ 13 🗑️ 312

models

MODULAR CABINETS

30" X 24½" 36" X 24½" ◀ 48" X 24½" ▶ 60" X 24½"



500KD32-0501F- -
◆ 32½ 🚗 5 📦 108



500KD40-0501F- -
◆ 40¼ 🚗 5 📦 96



500KD40-0701F-K0-A1
◆ 40¼ 🚗 7 📦 156



500KD40-0702F- -
◆ 40¼ 🚗 7 📦 156



500KD40-0801F- -
◆ 40¼ 🚗 8 📦 192



500KD40-0901F- -
◆ 40¼ 🚗 9 📦 216



500KD60-0801F- -
◆ 60 🚗 8 📦 156



500KD60-0901F- -
◆ 60 🚗 9 📦 216



500KD60-1001F-K0-A1
◆ 60 🚗 10 📦 228



METALIA
inStock[®]
REAL-TIME STOCKS // READY TO SHIP

Get an exclusive access to our real-time inventory on our Distributor Portal.

Don't have your login info yet? Contact us at info@metalia.com to get started.

models
MODULAR CABINETS

30" X 24½" 36" X 24½" 48" X 24½" ◀ 60" X 24½"



505MD32-1001F- □ □ - □
 ◆ 32½" ◀ 1 ▢ 12
 ◀ 5 ▢ 30 ▶ 4 ▢ 24



500MD40-0501F- □ □ - □
 ◆ 40¼ ◀ 5 ▢ 120



500MD40-0701F- □ □ - □
 ◆ 40¼ ◀ 7 ▢ 204



500MD40-0801F- □ □ - □
 ◆ 40¼ ◀ 8 ▢ 256

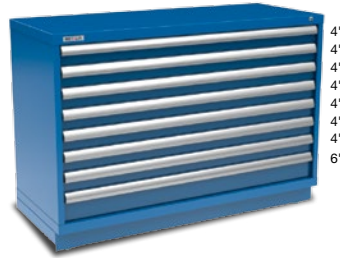

500MD40-0802F- □ □ - □
 ◆ 40¼ ◀ 8 ▢ 256



500MD40-0901F- □ □ - □
 ◆ 40¼ ◀ 9 ▢ 288



500MD40-1001F- □ □ - □
 ◆ 40¼ ◀ 10 ▢ 320



500MD60-0901F- □ □ - □
 ◆ 60 ◀ 9 ▢ 248



500MD60-1001F- □ □ - □
 ◆ 60 ◀ 10 ▢ 280

MOBILE CABINET MODELS

All cabinet models include a side handle, heavy-duty 5" Colson casters, forklift base with front cover, partitions and dividers. See all accessories on pages 22 & 23.

To complete your order:

501DD32-0601F- -



Type of lock:
D: Digital lock
K: Key lock



"One-drawer-at-a-time*" system:
0: Without
1: With (🔴 recommended)



Color code:
See all colors on page 41.



501DD32-0601F- -
◀ 30" ▶ 24½" ◆ 39" 🚚 6 📦 135



501DD40-0601F- -
◀ 30" ▶ 24½" ◆ 46¾" 🚚 6 📦 135



501GD32-0502F- -
◀ 36" ▶ 24½" ◆ 39" 🚚 5 📦 120



501KD32-0501F- -
◀ 48" ▶ 24½" ◆ 39" 🚚 5 📦 108



501KD40-0701F- -
◀ 48" ▶ 24½" ◆ 46¾" 🚚 7 📦 156



501KD40-0702F- -
◀ 48" ▶ 24½" ◆ 46¾" 🚚 7 📦 156



506MD32-1002F- -
◀ 60" (30"+30") ▶ 24½" ◆ 39"
🚚 5 📦 110 🚚 5 📦 106



506MD32-1001F- -
◀ 60" ▶ 24½" ◆ 39"
🚚 1 📦 12
🚚 5 📦 30 🚚 4 📦 24



506GDD32-0701F- -
◀ 66" (36"+30") ▶ 24½" ◆ 39"
🚚 5 📦 120 🚚 2 📦 12

* Coming Soon

1- SELECT YOUR HOUSING

◀	↕	↕	[↕]	
30"	24 1/2"	32"	26"	<input type="checkbox"/>
30"	24 1/2"	40"	34"	<input type="checkbox"/>
36"	24 1/2"	32"	26"	<input type="checkbox"/>
36"	24 1/2"	40"	34"	<input type="checkbox"/>
36"	24 1/2"	60"	54"	<input type="checkbox"/>
48"	24 1/2"	32"	26"	<input checked="" type="checkbox"/>
48"	24 1/2"	40"	34"	<input type="checkbox"/>
48"	24 1/2"	60"	54"	<input type="checkbox"/>
60"	24 1/2"	32"	26"	<input type="checkbox"/>
60"	24 1/2"	40"	34"	<input type="checkbox"/>
60"	24 1/2"	60"	54"	<input type="checkbox"/>

Forklift base options



F (flush) **R*** (recess)

* Not available for ↕ 60" cabinets

3- ACCESSORIES

- Stainless Steel Top
- Butcher Block Top
- LED drawer lighting (requires a top)
- Stainless Steel Backplate with power bar
- External locking bar
 - Key padlock
- Drawer lining
 - Slip-resistant Neoprene Mesh
 - Foam for tools
- Label holder
- Digital locking system
- Heavy-duty 5" Colson® casters (Set of 4)

Available for flush forklift base cabinets only.
- Side handle

4- COLOR

A1 (See color chart on page 41)

2- CONFIGURE YOUR DRAWERS

(A) Specify the desired height of each drawer. Available heights are 3", 4", 5", 6", 8", 10", 12", 14".

(B) Specify the compartment layout for each drawer. Refer to the partitions and dividers layouts on page 21.

Total drawer height must be equal to the housing's internal height [↕]

A

[↕]

"

"

"

"

"

"

"

"

"

"

"

"

"

"

"

"

"

"

"

"

B

METALIA ⓘ

#550KD 03 - 0518

#550KD 03 - 0506

#550KD 04 - 0506

#550KD 04 - 1033

#550KD 04 - 1033

#550KD 08 - 1044

EXAMPLE

MODULAR DRAWERS

MODULAR DRAWER MODELS

Shelving not included. See all accessories on pages 22 & 23. To complete your order, add the color code at the end of the product number (ex.: 520GD24-0501-**A1** for a Metalia® Blue drawers). See all colors on page 41.

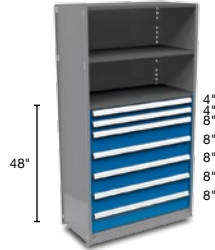
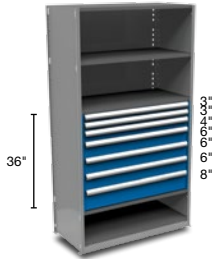

#	Icon	Icon	Icon	Icon	#	Icon	Icon	Icon	Icon	#	Icon	Icon	Icon	Icon
520GC36-0701-___	7	36"x 18"x 36"	152	520GC48-0701-___	7	36"x 18"x 48"	88	520GC48-0801-___	8	36"x 18"x 48"	192			
520GD36-0701-___	7	36"x 24½"x 36"	150	520GD48-0701-___	7	36"x 24½"x 48"	78	520GD48-0801-___	8	36"x 24½"x 48"	192			
520KC36-0701-___	7	48"x 18"x 36"	192	520KC48-0701-___	7	48"x 18" x 48"	132	520KC48-0801-___	8	48"x 18"x 48"	192			
520KD36-0701-___	7	48"x 24½"x 36"	156	520KD48-0701-___	7	48"x 24½"x48"	108	520KD48-0801-___	8	48"x 24½"x 48"	192			



NEW PRODUCT!
PLEASE INQUIRE FOR LEAD TIME.

1- SELECT YOUR DRAWER BANK

◀	↗	▶	
36"	18"	24"	<input type="checkbox"/>
36"	18"	36"	<input type="checkbox"/>
36"	18"	48"	<input type="checkbox"/>
36"	24 1/2"	24"	<input type="checkbox"/>
36"	24 1/2"	36"	<input type="checkbox"/>
36"	24 1/2"	48"	<input type="checkbox"/>
48"	18"	24"	<input type="checkbox"/>
48"	18"	36"	<input type="checkbox"/>
48"	18"	48"	<input type="checkbox"/>
48"	24 1/2"	24"	<input type="checkbox"/>
48"	24 1/2"	36"	<input checked="" type="checkbox"/>
48"	24 1/2"	48"	<input type="checkbox"/>

3- SELECT THE MOUNTING BRACKET NEEDED

- MetalWare™ (old design)
- MetalWare™ (new design)
- MetalWare™ WideSpan
- NAS5000 - Trim Line™
- NAS7000 - Type-One™
- Western Pacific Shelving System™
- Borroughs™ 1
- Penco™ 1
- SpaceSaver™ 1
- Rousseau Spider™ 1
- Tri-Boro™ 1
- Q-Shelf™ 1
- Hallowell™ 1
- Mecalux™ 1

Trademarks are the property of their respective companies and are used for information purposes only.

1 New product. Please inquire for lead time.

4- ACCESSORIES

- Drawer lining
 - Slip-resistant Neoprene Mesh
 - Foam for tools
- LED drawer lighting
- Label holder

2- CONFIGURE YOUR DRAWERS

(A) Specify the desired height of each drawer. Available heights are 3", 4", 5", 6", 8", 10", 12", 14".

A

◄ 36" ►

4"

4"

4"

8"

8"

8"

"

"

"

"

"

"

"

"

"

"

"

"

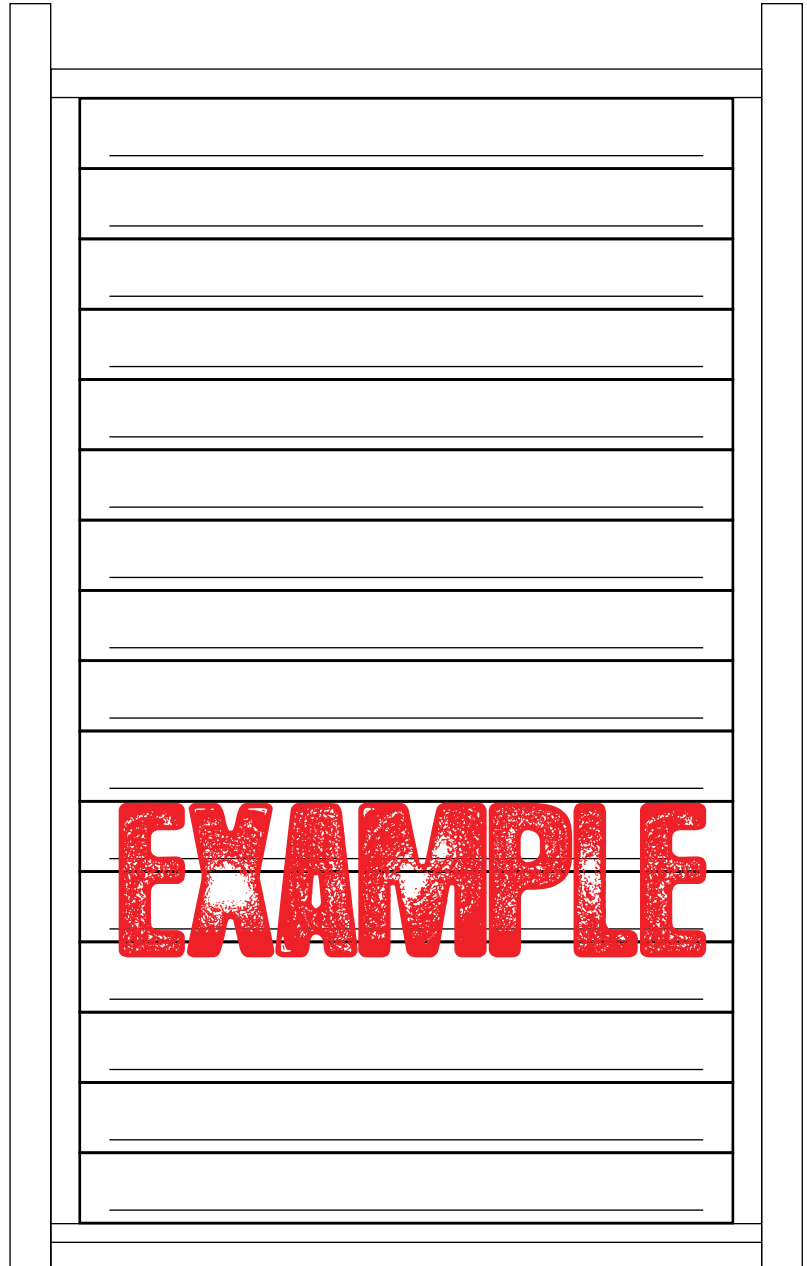

5- COLOR

- 40" Door kit for Metalware™ shelving (above the drawers only)
- External locking bar
 - Key padlock

A1 (See color chart on page 41)

Download the Build Your Own Modular Drawer order form on metalia.com

DRAWER DIMENSIONS

HEIGHT

3"
4"
5"
6"
8"
10"
12"
14"

DEPTH

18"
Modular drawers only.
24½"

WIDTH

30"
36"
48"
60"

24½"

18"

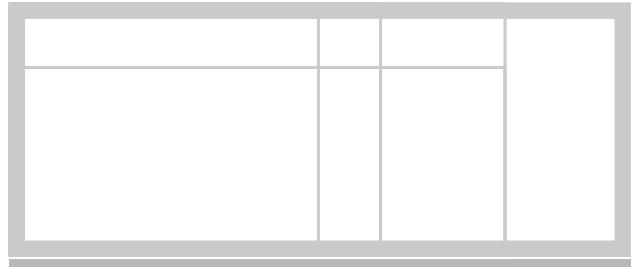

30"

36"

48"

60"

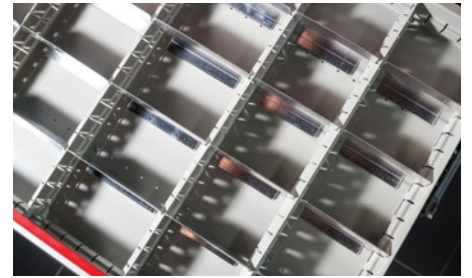
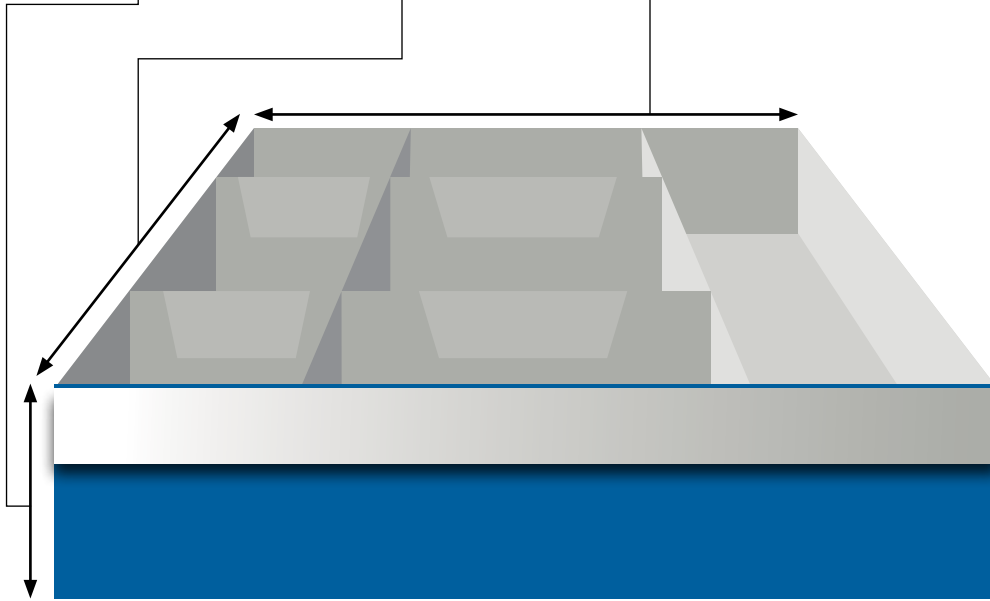

NEW PRODUCT!
PLEASE INQUIRE FOR LEAD TIME.

ROLL-OUT SHELVES

Configurations for Modular drawers only.

Drawer dimensions	30" X 24½"	36" X 24½"	48" X 24½"	60" X 24½"	36" X 18"	48" x 18"
Roll-out shelf — Front access	111DD03-0001	111GD03-0001	111KD03-0001	111MD03-0001	111GC03-0001	111KC03-0001
Roll-out shelf — 3-sided access	111DD03-0002	111GD03-0002	111KD03-0002	111MD03-0002	111GC03-0002	111KC03-0002

PARTITIONS

DRAWER HEIGHT

PARTITION DEPTH	3"	4"	5"	6"	8"	10"	12" & 14"
18"	131ZC03-0001	131ZC04-0001	131ZC05-0001	131ZC06-0001	131ZC08-0001	131ZC10-0001	131ZC12-0001
24½"	131ZD03-0001	131ZD04-0001	131ZD05-0001	131ZD06-0001	131ZD08-0001	131ZD10-0001	131ZD12-0001

DIVIDERS

DIVIDER WIDTH	3"	4"	5"	6"	8"	10"	12" & 14"
3"	130-0303	130-0403	130-0503	130-0603	x	x	x
4"	130-0304	130-0404	130-0504	130-0604	x	x	x
5"	130-0305	130-0405	130-0505	130-0605	130-0805	x	x
6"	130-0306	130-0406	130-0506	130-0606	130-0806	130-1006	x
7"	130-0307	130-0407	130-0507	130-0607	130-0807	130-1007	130-1207
8"	130-0308	130-0408	130-0508	130-0608	130-0808	130-1008	130-1208
9"	130-0309	130-0409	130-0509	130-0609	130-0809	130-1009	130-1209
10"	130-0310	130-0410	130-0510	130-0610	130-0810	130-1010	130-1210
11"	130-0311	130-0411	130-0511	130-0611	130-0811	130-1011	130-1211

AVAILABLE DRAWER LAYOUTS

Complete the product number with the selected drawer height (ex.: #550DD04-0304 for a 4" high drawer).

Available drawer heights: 3", 4", 5", 6", 8", 10", 12", 14".

◀▶ 30" x 24 1/2"

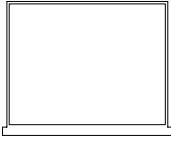
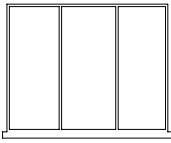
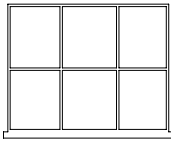
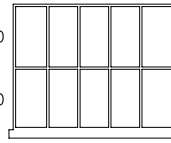
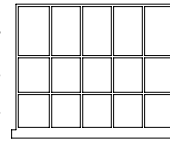
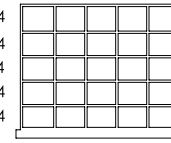
26 	8 10 8 	8 10 8 	5 5 6 5 5 	5 5 6 5 5 	5 5 6 5 5 
#1 #110DD ____-0001	#3 #550DD ____-0200	#6 #550DD ____-0203	#10 #550DD ____-0405	#15 #550DD ____-0410	#25 #550DD ____-0420



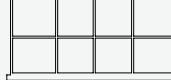
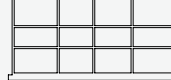
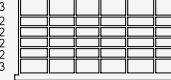

◀▶ 36" x 18"

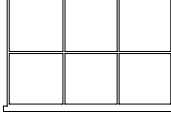
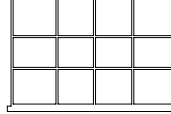
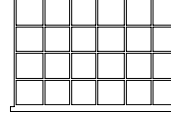
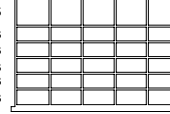
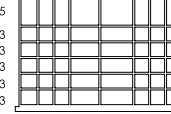
32 	11 10 11 	8 8 8 8 	8 8 8 8 	5 5 6 6 5 5 	5 5 6 6 5 5 
#1 #110GC ____-0001	#6 #550GC ____-0203	#8 #550GC ____-0304	#12 #550GC ____-0308	#24 #550GC ____-0518	#36 #550GC ____-0530



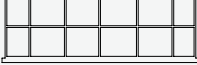
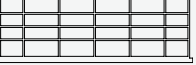

◀▶ 36" x 24 1/2"

32 	11 10 11 	8 8 8 8 	5 5 6 6 5 5 	7 6 6 6 7 	3 3 3 7 7 3 3 3 
#1 #110GD ____-0001	#6 #550GD ____-0203	#12 #550GD ____-0308	#24 #550GD ____-0518	#30 #550GD ____-0425	#48 #550GD ____-0740



◀▶ 48" x 18"

44 	8 9 10 9 8 	6 8 8 8 8 6 	6 8 8 8 8 6 	8 7 7 7 7 8 	3 3 6 6 6 6 4 3 3 
#1 #110KC ____-0001	#5 #550KC ____-0400	#12 #550KC ____-0506	#24 #550KC ____-0518	#36 #550KC ____-0530	#54 #550KC ____-0845

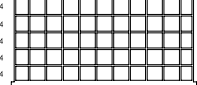
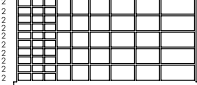
◀▶ 48" x 24 1/2"

44 	8 7 7 7 7 8 	8 7 7 7 7 8 	4 4 4 4 4 4 4 4 4 4 	4 4 4 4 4 4 4 4 4 4 	3 3 3 4 5 5 6 6 9 
#1 #110KD ____-0001	#12 #550KD ____-0506	#24 #550KD ____-0518	#44 #550KD ____-1033	#55 #550KD ____-1044	#60 #550KD ____-0851

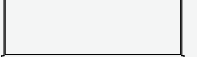
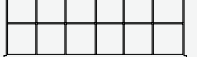
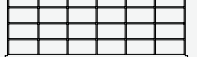
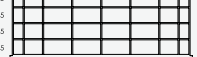
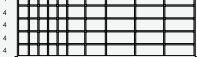
◀▶ 60" x 24 1/2"

56 	10 9 9 9 9 10 	10 9 9 9 9 10 	4 6 9 9 9 9 6 4 	3 3 3 3 7 7 9 9 9 	6 5 5 5 5 5 5 5 6 
#1 #110MD ____-0001	#12 #550MD ____-0506	#24 #550MD ____-0518	#32 #550MD ____-0724	#50 #550MD ____-0940	#77 #550MD ____-1066

STANDARD COMPARTMENTS PER DRAWER

Drawer dimensions	Configurations for Modular drawers only.					
	30" X 24 1/2"	36" X 24 1/2"	48" X 24 1/2"	60" X 24 1/2"	36" X 18"	48" x 18"
3"	25 (0420)	24 (0518)	24 (0518)	32 (0724)	24 (0518)	36 (0530)
4"	25 (0420)	24 (0518)	24 (0518)	32 (0724)	24 (0518)	36 (0530)
5"	25 (0420)	24 (0518)	24 (0518)	32 (0724)	24 (0518)	36 (0530)
6"	25 (0420)	24 (0518)	24 (0518)	32 (0724)	24 (0518)	24 (0518)
8"	10 (0405)	6 (0203)	12 (0506)	12 (0506)	8 (0304)	12 (0506)
10" to 14"	6 (0203)	6 (0203)	12 (0506)	12 (0506)	6 (0203)	5 (0400)

NEW PRODUCT!
PARTITION DIVIDER
PUB/LEADLINE

NEW PRODUCT!
PARTITION DIVIDER
PUB/LEADLINE

MODULAR CABINET AND MODULAR DRAWER ACCESSORIES



NEW PRODUCT!
PLEASE INQUIRE FOR LEAD TIME.



NEW PRODUCT!
PLEASE INQUIRE FOR LEAD TIME.



Neoprene Mesh #135



Foam for tools #136

LED DRAWER LIGHTING (REQUIRES A TOP)

Product #	Description
221DZ00-0001	↔ 30" cabinet
221GZ00-0001	↔ 36" cabinet
221KZ00-0001	↔ 48" cabinet
221MZ00-0001	↔ 60" cabinet
122GZ02-0001	↔ 36" modular drawers
122KZ02-0001	↔ 48" modular drawers

"ONE-DRAWER-AT-A-TIME" SYSTEM

Product #	Description
315ZZ26-0001	◆ 32½" cabinet (26" internal)
315ZZ34-0001	◆ 40¼" cabinet (34" internal)
315ZZ54-0001	◆ 60" cabinet (54" internal)

EXTERNAL LOCKING BAR

(COMPLETE THE PRODUCT NUMBER WITH "1" FOR KEY AND "2" FOR PADLOCK)

Product #	Description
140ZZ26-000_()	◆ 32½" cabinet (26" internal)
140ZZ34-000_()	◆ 40¼" cabinet (34" internal)
140ZZ54-000_()	◆ 60" cabinet (54" internal)
140ZZ24-000_()	◆ 24" modular drawers
140ZZ36-000_()	◆ 36" modular drawers
140ZZ48-000_()	◆ 48" modular drawers

DRAWER LOCK-IN MECHANISM

Product #	Description
309DZ00-0001	↔ 30" cabinet
309GZ00-0001	↔ 36" cabinet
309KZ00-0001	↔ 48" cabinet
309MZ00-0001	↔ 60" cabinet

DRAWER LINING

Product # (Neoprene)	Description	Product # (Foam)	Description
135DD	↔ 30" x ▣ 24½"	136DD	↔ 30" x ▣ 24½"
135GC	↔ 36" x ▣ 18"	136GC	↔ 36" x ▣ 18"
135GD	↔ 36" x ▣ 24½"	136GD	↔ 36" x ▣ 24½"
135KC	↔ 48" x ▣ 18"	136KC	↔ 48" x ▣ 18"
135KD	↔ 48" x ▣ 24½"	136KD	↔ 48" x ▣ 24½"
135MD	↔ 60" x ▣ 24½"	136MD	↔ 60" x ▣ 24½"



STAINLESS STEEL BACKPLATE WITH POWER BAR

Product #	Description
237DZ04-0011	↔ 30" cabinet
237GZ04-0011	↔ 36" cabinet
237KZ04-0011	↔ 48" cabinet
237MZ04-0011	↔ 60" cabinet

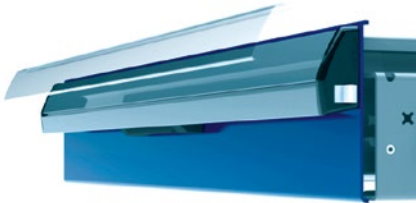

LABEL HOLDER

Product #	Description
307DZ00-0001	↔ 30" drawers
307GZ00-0001	↔ 36" drawers
307KZ00-0001	↔ 48" drawers
307MZ00-0001	↔ 60" drawers

NEW PRODUCT!
PLEASE INQUIRE FOR LEAD TIME.



DIGITAL LOCKING SYSTEM

Product #	Description
302ZZ00-0001	Digital locking system for cabinets



MOBILITY ACCESSORIES

Product #	Description
150ZZ05-0001	Heavy-duty 5" Colson® casters with steel brake system. Set of 2 swivel, 2 fixed. Total height : 6½". Not available for ↕ 60" cabinet.



151ZZ00-0001	Side handle
---------------------	-------------

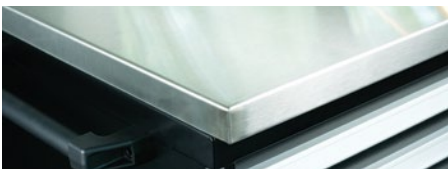

Stainless Steel Top #210

AVAILABLE CABINET TOPS

Product # (Stainless steel)	Description	Product # (Butcher block)	Description
210DD	↔ 30" x ▣ 24½"	211DD	↔ 30" x ▣ 24½"
210GD	↔ 36" x ▣ 24½"	211GD	↔ 36" x ▣ 24½"
210KD	↔ 48" x ▣ 24½"	211KD	↔ 48" x ▣ 24½"
210MD	↔ 60" x ▣ 24½"	211MD	↔ 60" x ▣ 24½"



Butcher Block Top #211



METALIA



METALIA





WR2S

WORKSTATIONS

WRS WORKSTATIONS

SUPERCHARGE YOUR SERVICE DEPARTMENT'S WORKFLOW

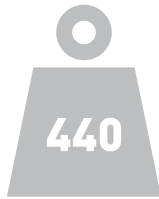

440 LB CAPACITY PER DRAWER

10% more than industry standard.

What's in it for you?

- Store more in less space.
- Eliminates deformation of the drawer.
- Less strain on the unit, improved lifetime.

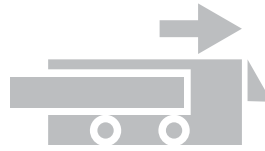

SWISS-MADE SLIDING SYSTEM ON DELRIN® WITH SAFETY LOCK

NASA sourced material is used to create the world's best sliding system.

What's in it for you?

- Self-lubricating, maintenance free and keeps its properties in extreme temperatures.
- Ensures maximum reliability, precision and smoothness for the lifetime of the unit.
- Safety Lock system prevents drawers from accidentally falling out of the cabinet.

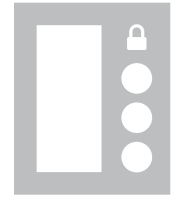

ONE PIECE, CAST ALUMINUM HANDLE WITH DIGITAL LOCK

The best handle in the industry.

What's in it for you?

- Safer storage for your technicians' personal items.
- Simplified access control for managers.
- Eliminates the need for tracking keys.
- Most durable, improved looks and image.
- Exclusive one-piece construction.



DIGITAL LOCKING SYSTEM

Better control, easier management.

What's in it for you?

- Simplified access control for managers with Master Code.
- Eliminates the need to track keys (loss, turnover).
- Millions of possibilities with an 8 digits code.

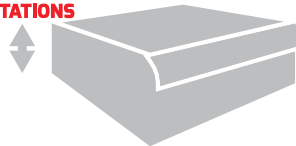

FULL HEIGHT DRAWER SIDEWALLS

Every cubic inch at your service.

What's in it for you?

- Prevents items from mixing or falling off drawer's sides.
- Maximize your investment by using every square inch available.
- Available in every drawer height.



ROLLED-EDGES DRAWER FACE

Durability on the frontline.

What's in it for you?

- 14 gauge steel for industry-leading stiffness and rigidity you can feel on every pull.
- Keeps drawer from bending under heavy load.
- Prevents wear and extends lifetime.



METALIA® LIFETIME WARRANTY

Store your worries away.

What's in it for you?

- Ensures high performance through the whole life cycle of the unit, limiting downtime.
- Peace of mind: All Metalia® products carry a Lifetime Warranty.

NEW TO
WRS
WORKSTATIONS



1¼" THICK, DOUBLE WALL STORAGE UNIT DOOR

The heaviest in the industry.

What's in it for you?

- Increased rigidity and durability of each unit.
- Eliminates the risk of deformation over time.



LED DRAWER LIGHTING

Focus on your productivity.

What's in it for you?

- Find what you are looking for faster, without relying on surrounding lighting.
- Effective in all drawers.

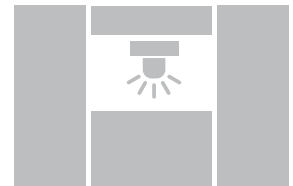

LED WORK SURFACE LIGHTING

A bright view on your task.

What's in it for you?

- Increase your productivity with a perfectly lit work surface.
- Energy efficient and extremely long lasting.



HEAVY-DUTY LEVELLING FEET

Built tough.

What's in it for you?

- Extra-large base with heavy-duty rubber.
- Designed to outlast the life expectancy of the unit.
- Simple and easy to adjust for perfect levelling.



ARTICULATED LIGHTING SYSTEM

Always by your side.

What's in it for you?

- 4000 lumens light up to 6' in front of the station.
- Eliminates the need for external light.
- Less electrical cord on the ground, less risk of injuries.



UNIQUE POWDER COATING

Great look, durable, amazing protection.

What's in it for you?

- The best protection against scratches, abrasion and corrosion.
- Ensures a top notch look for the lifetime of the unit.

WRS WORKSTATIONS

SUPERCARGE YOUR SERVICE DEPARTMENT'S WORKFLOW

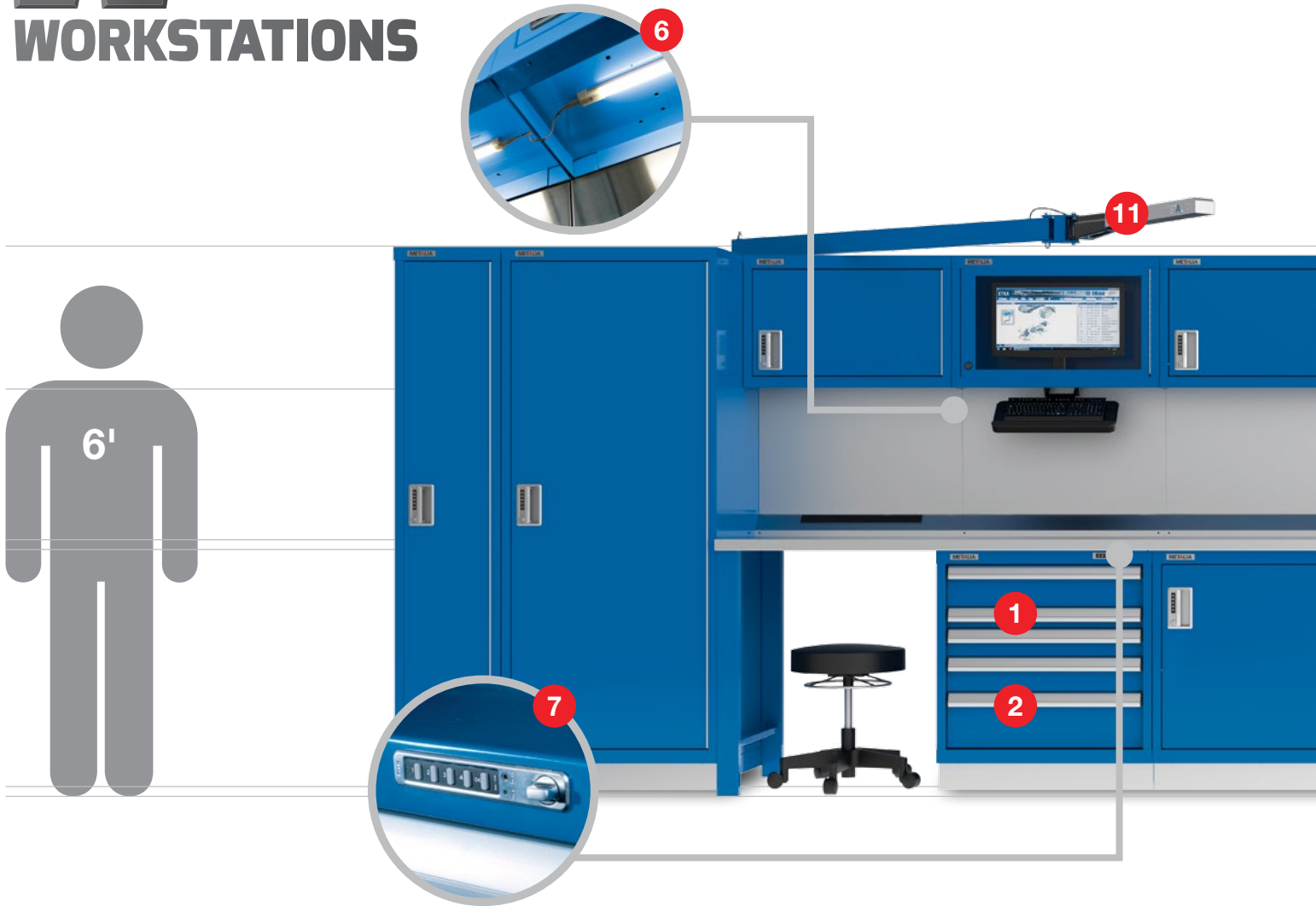

WHY CHOOSE A WRS WORKSTATION?



- 1 440 lb capacity per drawer**
10% more than industry standard.



- 2 Swiss-made sliding system on Delrin® with Safety Lock**
NASA sourced material is used to create the world's best sliding system.



- 3 One piece, cast aluminum handle with digital lock**
The best handle in the industry.



- 4 1¼" thick, double wall storage unit door**
The heaviest in the industry.



- 5 LED drawer lighting**
Focus on your productivity.



- 6 LED work surface lighting**
A bright view on your task.

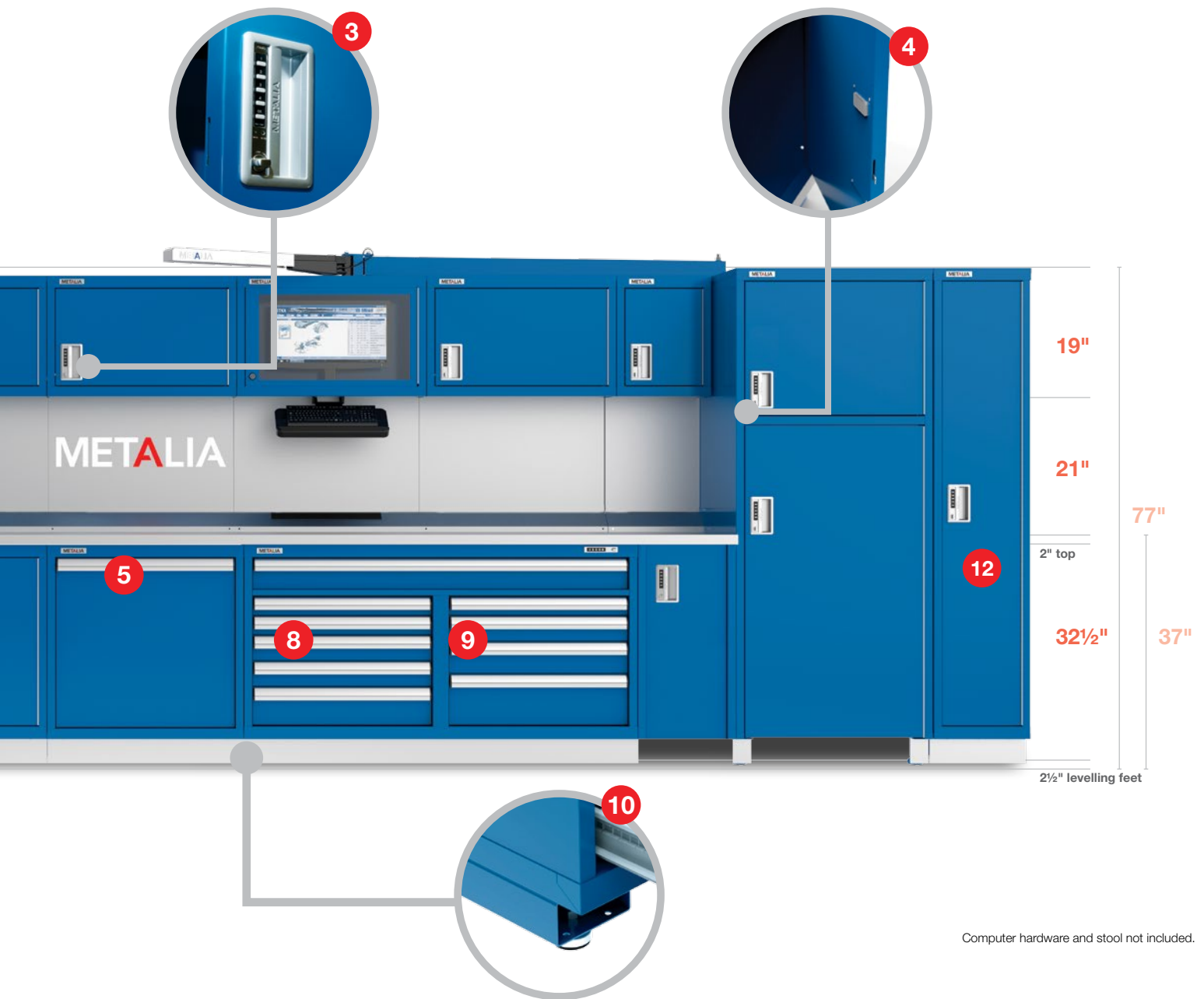

Computer hardware and stool not included.



7 Digital locking system
Better control, easier management.



8 Full height drawer sidewalls
Every cubic inch at your service.



9 Rolled-edges drawer face
Durability on the frontline.



10 Heavy-duty levelling feet
Built tough.



11 Articulated lighting system
Always by your side.



12 Unique powder coating
Great look, durable, amazing protection.



1 user



2 users

See all colors on page 41.

MW060-11-_____

◀ 60" X ▶ 24½" X ◆ 77"



qty	description	Product #
1	Medium storage unit, 30" x 24½" x 32½"	200DD32-0001
1	Workbench leg, 4" x 24½" x 32½"	215ZD32-0001
1	Workbench top, wood-filled / stainless steel, 60" x 25½" x 2"	210MD02-0001
3	Upright for head unit	235ZZ40-0001
1	Back stopper, stainless steel, 30" x 4" x 4"	237DZ04-0001
1	Back stopper with power bar (6 outlets), 30" x 4" x 4"	237DZ04-0002
2	Back panel, stainless steel, 30" x 2" x 21"	236DZ21-0001
1	Head storage unit, 30" X 12" X 19"	200DB19-0001
1	Head storage unit with glass door, 30" X 12" X 19"	200DB19-0002

Options

<input type="checkbox"/>	2	LED magnetic bar, 24½" x 1" x 2"	220CZ00-0001
<input type="checkbox"/>	2	Trim, stainless steel (bottom unit), 30" x 1/8" x 4"	260DZ00-0002
<input type="checkbox"/>	1	Trim, stainless steel (100 mm recess base), 30" x 1/8" x 4"	261DZ00-0001
<input type="checkbox"/>	1	Back panel with logo, 60" x 2" x 21"	236MZ21-0002

MW060-12-_____

◀ 60" X ▶ 24½" X ◆ 77"



qty	description	Product #
1	Cabinet 1 x 6", 1 x 3", 1 x 4", 1 x 5", 1 x 8", 30" X 24½" X 32½"	500DD32-0501R-D0
1	Workbench leg, 4" x 24½" x 32½"	215ZD32-0001
1	Workbench top, wood-filled / stainless steel, 60" x 25½" x 2"	210MD02-0001
3	Upright for head unit	235ZZ40-0001
2	Back panel, stainless steel, 30" x 2" x 21"	236DZ21-0001
1	Back stopper, stainless steel, 30" x 4" x 4"	237DZ04-0001
1	Back stopper with power bar (6 outlets), 30" x 4" x 4"	237DZ04-0002
1	Head storage unit, 30" X 12" X 19"	200DB19-0001
1	Head storage unit with glass door, 30" X 12" X 19"	200DB19-0002

Options

<input type="checkbox"/>	2	LED magnetic bar, 24½" x 1" x 2"	220CZ00-0001
<input type="checkbox"/>	1	LED light strip, 60" x 1" x 2"	221MZ00-0001
<input type="checkbox"/>	2	Trim, stainless steel (bottom unit), 30" x 1/8" x 4"	260DZ00-0002
<input type="checkbox"/>	1	Trim, stainless steel (100 mm recess base), 30" x 1/8" x 4"	261DZ00-0001
<input type="checkbox"/>	1	Back panel with logo, 60" x 2" x 21"	236MZ21-0002



1 user



2 users

MW060-13-_____

◀ 60" X ▶ 24½" X ◆ 77"



qty	description	Product #
2	Medium storage unit, 30" x 24½" x 32½"	200DD32-0001
1	Workbench top, wood-filled / stainless steel, 60" x 25½" x 2"	210MD02-0001
3	Upright for head unit	235ZZ40-0001
2	Back panel, stainless steel, 30" x 2" x 21"	236DZ21-0001
1	Back stopper, stainless steel, 30" x 4" x 4"	237DZ04-0001
1	Back stopper with power bar (6 outlets), 30" x 4" x 4"	237DZ04-0002
1	Head storage unit, 30" X 12" X 19"	200DB19-0001
1	Head storage unit with glass door, 30" X 12" X 19"	200DB19-0002

Options

<input type="checkbox"/>	2	LED magnetic bar, 24½" x 1" x 2"	220CZ00-0001
<input type="checkbox"/>	1	LED light strip, 60" x 1" x 2"	221MZ00-0001
<input type="checkbox"/>	2	Trim, stainless steel (bottom unit), 30" x ⅛" x 4"	260DZ00-0002
<input type="checkbox"/>	2	Trim, stainless steel (100 mm recess base), 30" x ⅛" x 4"	261DZ00-0001
<input type="checkbox"/>	1	Back panel with logo, 60" x 2" x 21"	236MZ21-0002

MW060-14-_____

◀ 60" X ▶ 24½" X ◆ 77"



qty	description	Product #
1	Cabinet 1 x 5" full width, L : 2 x 3", 2 x 4" 1 x 6" R : 1 x 3", 1 x 4", 1 x 5", 1 x 8", 60" x 24½" x 32½"	505MD32-1001R-D0
1	Workbench top, wood-filled / stainless steel, 60" x 25½" x 2"	210MD02-0001
3	Upright for head unit	235ZZ40-0001
2	Back panel, stainless steel, 30" x 2" x 21"	236DZ21-0001
1	Back stopper, stainless steel, 30" x 4" x 4"	237DZ04-0001
1	Back stopper with power bar (6 outlets), 30" x 4" x 4"	237DZ04-0002
1	Head storage unit, 30" X 12" x 19"	200DB19-0001
1	Head storage unit with glass door, 30" X 12" x 19"	200DB19-0002

Options

<input type="checkbox"/>	2	LED magnetic bar, 24½" x 1" x 2"	220CZ00-0001
<input type="checkbox"/>	1	LED light strip, 60" x 1" x 2"	221MZ00-0001
<input type="checkbox"/>	2	Trim, stainless steel (bottom unit), 30" x ⅛" x 4"	260DZ00-0002
<input type="checkbox"/>	1	Trim, stainless steel (100 mm recess base), 60" x ⅛" x 4"	261MZ00-0001
<input type="checkbox"/>	1	Back panel with logo, 60" x 2" x 21"	236MZ21-0002



1 user



2 users

**MW090-11-_____**

◀ 90" X ▶ 24½" X ◆ 77"

qty	description	Product #
2	Medium storage unit, 30" x 24½" x 32½"	200DD32-0001
1	Cabinet 1 x 6", 1 x 3", 1 x 4", 1 x 5", 1 x 8", 30" X 24½" X 32½"	500DD32-0501R-D0
1	Workbench top, wood-filled / stainless steel, 90" x 25½" x 2"	210RD02-0001
4	Upright for head unit	235ZZ40-0001
3	Back panel, stainless steel, 30" x 2" x 21"	236DZ21-0001
2	Back stopper, stainless steel, 30" x 4" x 4"	237DZ04-0001
1	Back stopper with power bar (6 outlets), 30" x 4" x 4"	237DZ04-0002
2	Head storage unit, 30" X 12" X 19"	200DB19-0001
1	Head storage unit with glass door, 30" X 12" X 19"	200DB19-0002

Options

<input type="checkbox"/>	3	LED magnetic bar, 24½" x 1" x 2"	220CZ00-0001
<input type="checkbox"/>	1	LED light strip, 90" x 1" x 2"	221RZ00-0001
<input type="checkbox"/>	3	Trim, stainless steel (bottom unit), 30" x 1/8" x 4"	260DZ00-0002
<input type="checkbox"/>	3	Trim, stainless steel (100 mm recess base), 30" x 1/8" x 4"	261DZ00-0001
<input type="checkbox"/>	1	Drawer cover, stainless steel, with logo, 30" x 1/8" x 4"	263DZ06-0001
<input type="checkbox"/>	1	Back panel with logo, 30" x 2" x 21"	236DZ21-0002



1 user



2 users



MW120-11-_____

↔ 120" X ↗ 24½" X ↕ 77"

qty	description	Product #
1	Cabinet 1 x 5" full width, L : 2 x 3", 2 x 4" 1 x 6" R : 1 x 3", 1 x 4", 1 x 5", 1 x 8", 60" x 24½" x 32½"	505MD32-1001R-D0
1	Utility drawer, 30" x 24½" x 32½"	201DD32-0011
1	Mobile cart, 13" x 23" x 31"	230ZD31-0001
1	Tall storage unit with open base & 2 doors, 30" x 24½" x 74½"	200DD74-0002
1	Workbench top, wood-filled / stainless steel, 90" x 25½" x 2"	210RD02-0001
4	Upright for head unit	235ZZ40-0001
3	Back panel, stainless steel, 30" x 2" x 21"	236DZ21-0001
2	Back stopper, stainless steel, 30" x 4" x 4"	237DZ04-0001
1	Back stopper with power bar (6 outlets), 30" x 4" x 4"	237DZ04-0002
2	Head storage unit, 30" X 12" X 19"	200DB19-0001
1	Head storage unit with glass door, 30" X 12" X 19"	200DB19-0002

Options

<input type="checkbox"/>	3	LED magnetic bar, 24½" x 1" x 2"	220CZ00-0001
<input type="checkbox"/>	1	LED light strip, 90" x 1" x 2"	221RZ00-0001
<input type="checkbox"/>	1	Trim, stainless steel (100 mm recess base), 30" x ⅛" x 4"	261DZ00-0001
<input type="checkbox"/>	1	Trim, stainless steel (100 mm recess base), 60" x ⅛" x 4"	261MZ00-0001
<input type="checkbox"/>	1	Drawer cover, stainless steel, with logo, 60" x ⅛" x 6"	263MZ06-0001
<input type="checkbox"/>	1	Back panel with logo, 30" x 2" x 21"	236DZ21-0002



1 user



2 users

**MW120-12-_____**

◀ 120" X ▶ 24½" X ◆ 77"

qty	description	Product #
1	Cabinet 1 x 5" full width, L : 2 x 3", 2 x 4" 1 x 6" R : 1 x 3", 1 x 4", 1 x 5", 1 x 8", 60" x 24½" x 32½"	505MD32-1001R-D0
1	Cabinet 1 x 6", 1 x 3", 1 x 4", 1 x 5", 1 x 8", 30" X 24½" X 32½"	500DD32-0501R-D0
1	Tall storage unit with clothes hanging pole, 15" x 24½" x 74½"	200AD74-0001
1	Pull-out tower unit, 15" x 24½" x 74½"	201AD74-0001
1	Workbench top, wood-filled / stainless steel, 90" x 25½" x 2"	210RD02-0001
4	Upright for head unit	235ZZ40-0001
3	Back panel, stainless steel, 30" x 2" x 21"	236DZ21-0001
2	Back stopper, stainless steel, 30" x 4" x 4"	237DZ04-0001
1	Back stopper with power bar (6 outlets), 30" x 4" x 4"	237DZ04-0002
2	Head storage unit, 30" X 12" X 19"	200DB19-0001
1	Head storage unit with glass door, 30" X 12" X 19"	200DB19-0002

Options

<input type="checkbox"/>	3	LED magnetic bar, 24½" x 1" x 2"	220CZ00-0001
<input type="checkbox"/>	1	LED light strip, 90" x 1" x 2"	221RZ00-0001
<input type="checkbox"/>	3	Trim, stainless steel (bottom unit), 30" x ⅛" x 4"	260DZ00-0002
<input type="checkbox"/>	2	Trim, stainless steel (100 mm recess base), 15" x ⅛" x 4"	261AZ00-0001
<input type="checkbox"/>	1	Trim, stainless steel (100 mm recess base), 30" x ⅛" x 4"	261DZ00-0001
<input type="checkbox"/>	1	Trim, stainless steel (100 mm recess base), 60" x ⅛" x 4"	261MZ00-0001
<input type="checkbox"/>	1	Drawer cover, stainless steel, with logo, 60" x ⅛" x 6"	263MZ06-0001
<input type="checkbox"/>	1	Drawer cover, stainless steel, with logo, 30" x ⅛" x 6"	263DZ06-0001
<input type="checkbox"/>	1	Back panel with logo, 30" x 2" x 21"	236DZ21-0002



MW120-21-_____

↔ 120" X ↗ 24½" X ↕ 77"

qty	description	Product #
1	Cabinet 1 x 5" full width, L : 2 x 3", 2 x 4" 1 x 6" R : 1 x 3", 1 x 4", 1 x 5", 1 x 8", 60" x 24½" x 32½"	505MD32-1001R-D0
1	Cabinet 1 x 6", 1 x 3", 1 x 4", 1 x 5", 1 x 8", 30" X 24½" X 32½"	500DD32-0501R-D0
1	Utility drawer, 30" x 24½" x 32½"	201DD32-0011
2	Workbench top, wood-filled / stainless steel, 60" x 25½" x 2"	210MD02-0001
5	Upright for head unit	235ZZ40-0001
4	Back panel, stainless steel, 30" x 2" x 21"	236DZ21-0001
3	Back stopper, stainless steel, 30" x 4" x 4"	237DZ04-0001
1	Back stopper with power bar (6 outlets), 30" x 4" x 4"	237DZ04-0002
4	Head storage unit, 30" X 12" X 19"	200DB19-0001

Options

<input type="checkbox"/>	4	LED magnetic bar, 24½" x 1" x 2"	220CZ00-0001
<input type="checkbox"/>	2	LED light strip, 60" x 1" x 2"	221MZ00-0001
<input type="checkbox"/>	4	Trim, stainless steel (bottom unit), 30" x 1/8" x 4"	260DZ00-0002
<input type="checkbox"/>	2	Trim, stainless steel (100 mm recess base), 30" x 1/8" x 4"	261DZ00-0001
<input type="checkbox"/>	1	Trim, stainless steel (100 mm recess base), 60" x 1/8" x 4"	261MZ00-0001
<input type="checkbox"/>	1	Drawer cover, stainless steel, with logo, 60" x 1/8" x 6"	263MZ06-0001
<input type="checkbox"/>	1	Drawer cover, stainless steel, with logo, 30" x 1/8" x 6"	263DZ06-0001
<input type="checkbox"/>	1	Back panel with logo, 60" x 2" x 21"	236MZ21-0002



1 user



2 users

**MW120-22-_____**

◀ 120" X ▶ 24½" X ◆ 77"

qty	description	Product #
2	Cabinet 1 x 5" full width, L : 2 x 3", 2 x 4" 1 x 6" R : 1 x 3", 1 x 4", 1 x 5", 1 x 8", 60" x 24½" x 32½"	505MD32-1001R-D0
2	Workbench top, wood-filled / stainless steel, 60" x 25½" x 2"	210MD02-0001
5	Upright for head unit	235ZZ40-0001
4	Back panel, stainless steel, 30" x 2" x 21"	236DZ21-0001
2	Back stopper, stainless steel, 30" x 4" x 4"	237DZ04-0001
2	Back stopper with power bar (6 outlets), 30" x 4" x 4"	237DZ04-0002
2	Head storage unit, 30" X 12" X 19"	200DB19-0001
2	Head storage unit with glass door, 30" X 12" X 19"	200DB19-0002

Options

<input type="checkbox"/>	4	LED magnetic bar, 24½" x 1" x 2"	220CZ00-0001
<input type="checkbox"/>	2	LED light strip, 60" x 1" x 2"	221MZ00-0001
<input type="checkbox"/>	4	Trim, stainless steel (bottom unit), 30" x 1/8" x 4"	260DZ00-0002
<input type="checkbox"/>	2	Trim, stainless steel (100 mm recess base), 60" x 1/8" x 4"	261MZ00-0001
<input type="checkbox"/>	2	Drawer cover, stainless steel, with logo, 60" x 1/8" x 6"	263MZ06-0001
<input type="checkbox"/>	1	Back panel with logo, 60" x 2" x 21"	236MZ21-0002



1 user



2 users



MW150-21-_____

◆ 150" X ▣ 24½" X ◆ 77"

qty	description	Product #
3	Medium storage unit, 30" x 24½" x 32½"	200DD32-0001
2	Tall storage unit with 3 shelves, 30" x 24½" x 74½"	200DD74-0001
1	Workbench top, wood-filled / stainless steel, 90" x 25½" x 2"	210RD02-0001
4	Upright for head unit	235ZZ40-0001
3	Back panel, stainless steel, 30" x 2" x 21"	236DZ21-0001
2	Back stopper, stainless steel, 30" x 4" x 4"	237DZ04-0001
1	Back stopper with power bar (6 outlets), 30" x 4" x 4"	237DZ04-0002
2	Head storage unit, 30" X 12" X 19"	200DB19-0001
1	Head storage unit with glass door, 30" X 12" X 19"	200DB19-0002

Options

<input type="checkbox"/>	3	LED magnetic bar, 24½" x 1" x 2"	220CZ00-0001
<input type="checkbox"/>	1	LED light strip, 90" x 1" x 2"	221RZ00-0001
<input type="checkbox"/>	3	Trim, stainless steel (bottom unit), 30" x 1/8" x 4"	260DZ00-0002
<input type="checkbox"/>	5	Trim, stainless steel (100 mm recess base), 30" x 1/8" x 4"	261DZ00-0001
<input type="checkbox"/>	1	Back panel with logo, 30" x 2" x 21"	236DZ21-0002



1 user



2 users

**MW180-21-_____**

◆ 180" X ▣ 24½" X ◆ 77"

qty	description	Product #
2	Cabinet 1 x 5" full width, L : 2 x 3", 2 x 4" 1 x 6" R : 1 x 3", 1 x 4", 1 x 5", 1 x 8", 60" x 24½" x 32½"	505MD32-1001R-D0
2	Tall storage unit with 3 shelves, 30" x 24½" x 74½"	200DD74-0001
2	Workbench top, wood-filled / stainless steel, 60" x 25½" x 2"	210MD02-0001
5	Upright for head unit	235ZZ40-0001
4	Back panel, stainless steel, 30" x 2" x 21"	236DZ21-0001
2	Back stopper, stainless steel, 30" x 4" x 4"	237DZ04-0001
2	Back stopper with power bar (6 outlets), 30" x 4" x 4"	237DZ04-0002
2	Head storage unit, 30" X 12" X 19"	200DB19-0001
2	Head storage unit with glass door, 30" X 12" X 19"	200DB19-0002

Options

<input type="checkbox"/>	4	LED magnetic bar, 24½" x 1" x 2"	220CZ00-0001
<input type="checkbox"/>	2	LED light strip, 60" x 1" x 2"	221MZ00-0001
<input type="checkbox"/>	4	Trim, stainless steel (bottom unit), 30" x 1/8" x 4"	260DZ00-0002
<input type="checkbox"/>	2	Trim, stainless steel (100 mm recess base), 60" x 1/8" x 4"	261MZ00-0001
<input type="checkbox"/>	2	Trim, stainless steel (100 mm recess base), 30" x 1/8" x 4"	261DZ00-0001
<input type="checkbox"/>	2	Drawer cover, stainless steel, with logo, 60" x 1/8" x 6"	263MZ06-0001
<input type="checkbox"/>	1	Back panel with logo, 60" x 2" x 21"	236MZ21-0002



MW180-22-_____

◀ 180" X ▶ 24½" X ◆ 77"

qty	description	Product #
2	Cabinet 1 x 5" full width, L : 2 x 3", 2 x 4" 1 x 6" R : 1 x 3", 1 x 4", 1 x 5", 1 x 8", 60" x 24½" x 32½"	505MD32-1001R-D0
2	Medium storage unit, 30" x 24½" x 32½"	200DD32-0001
2	Workbench top, wood-filled / stainless steel, 90" x 25½" x 2"	210RD02-0001
7	Upright for head unit	235ZZ40-0001
6	Back panel, stainless steel, 30" x 2" x 21"	236DZ21-0001
4	Back stopper, stainless steel, 30" x 4" x 4"	237DZ04-0001
2	Back stopper with power bar (6 outlets), 30" x 4" x 4"	237DZ04-0002
4	Head storage unit, 30" X 12" X 19"	200DB19-0001
2	Head storage unit with glass door, 30" X 12" X 19"	200DB19-0002

Options

<input type="checkbox"/>	6	LED magnetic bar, 24½" x 1" x 2"	220CZ00-0001
<input type="checkbox"/>	2	LED light strip, 90" x 1" x 2"	221RZ00-0001
<input type="checkbox"/>	6	Trim, stainless steel (bottom unit), 30" x 1/8" x 4"	260DZ00-0002
<input type="checkbox"/>	2	Trim, stainless steel (100 mm recess base), 60" x 1/8" x 4"	261MZ00-0001
<input type="checkbox"/>	2	Trim, stainless steel (100 mm recess base), 30" x 1/8" x 4"	261DZ00-0001
<input type="checkbox"/>	2	Drawer cover, stainless steel, with logo, 60" x 1/8" x 6"	263MZ06-0001
<input type="checkbox"/>	1	Back panel with logo, 60" x 2" x 21"	236MZ21-0002



1 user



2 users

**MW240-21-_____**

◆ 240" X ▣ 24½" X ◆ 77"

qty	description	Product #
2	Tall storage unit with 3 shelves, 30" x 24½" x 74½"	200DD74-0001
2	Cabinet 1 x 5" full width, L : 2 x 3", 2 x 4" 1 x 6" R : 1 x 3", 1 x 4", 1 x 5", 1 x 8", 60" x 24½" x 32½"	505MD32-1001R-D0
2	Mobile cart, 13" x 23" x 31"	230ZD31-0001
2	Door kit with frame, 15" x 3" x 30"	245AZ30-0001
1	Utility drawer, 30" x 24½" x 32½"	201DD32-0011
2	Workbench top, wood-filled / stainless steel, 90" x 25½" x 2"	210RD02-0001
7	Upright for head unit	235ZZ40-0001
6	Back panel, stainless steel, 30" x 2" x 21"	236DZ21-0001
4	Back stopper, stainless steel, 30" x 4" x 4"	237DZ04-0001
2	Back stopper with power bar (6 outlets), 30" x 4" x 4"	237DZ04-0002
4	Head storage unit, 30" X 12" X 19"	200DB19-0001
2	Head storage unit with glass door	200DB19-0002

Options

<input type="checkbox"/>	6	LED magnetic bar, 24½" x 1" x 2"	220CZ00-0001
<input type="checkbox"/>	2	LED light strip, 90" x 1" x 2"	221RZ00-0001
<input type="checkbox"/>	6	Trim, stainless steel (bottom unit), 30" x ⅛" x 4"	260DZ00-0002
<input type="checkbox"/>	2	Trim, stainless steel (bottom unit), 15" x ⅛" x 4"	260AZ00-0002
<input type="checkbox"/>	2	Trim, stainless steel (100 mm recess base), 60" x ⅛" x 4"	261MZ00-0001
<input type="checkbox"/>	3	Trim, stainless steel (100 mm recess base), 30" x ⅛" x 4"	261DZ00-0001
<input type="checkbox"/>	2	Drawer cover, stainless steel, with logo, 60" x ⅛" x 6"	263MZ06-0001
<input type="checkbox"/>	1	Back panel with logo, 60" x 2" x 21"	236MZ21-0002

Computer hardware not included.

AVAILABLE COLORS

Due to the printing process, colors might differ from those displayed here. Ask us for a sample before making your color choice.

STANDARD COLOR



 **A1** Metalia® Blue

PREMIUM COLORS

Longer production lead time and additional fees could apply.



 **A2** Indigo Blue



 **B1** Metalia® Red



 **C1** Black



 **E1** Metalia® Grey



 **D1** Orange



 **W1** Metalia® White

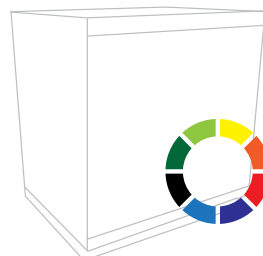

Z9 Custom

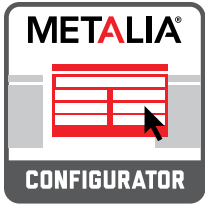

BUILD YOUR OWN WORKSTATION

Go to METALIA.COM/FR/CONFIGURATOR now to build the workstation you want!



Head units



Head storage unit,
15" x 12" x 19" *
200AB19-0001



Head storage unit,
30" x 12" x 19"
200DB19-0001



Head storage unit with glass
door, 30" x 12" x 19"
200DB19-0002



Counter tops



Workbench top, wood-filled / stainless steel
60" x 25½" x 2" 210MD02-0001
75" x 25½" x 2" * 210QD02-0001
90" x 25½" x 2" 210RD02-0001



Bottom units



Toolbox
60" x 24½" x 32½"
505MD32-1001R



Toolbox 30" x 24½" x 32½"
500DD32-0501R



Utility drawer, 30" x 24½" x 32½"
201DD32-0011



Utility drawer, 15" x 24½" x 32½"
201AD32-0011



Medium storage unit, 30" x 24½" x 32½"
200DD32-0001



Door kit with frame, 15" x 3" x 30"
245AZ30-0001



Workbench leg 4" x 24½" x 32½"
215ZD32-0001



Full-height units



Tall storage unit
with 3 shelves,
15" x 24½" x 74½" *
200AD74-0001



Tall storage unit
with 3 shelves,
30" x 24½" x 74½"
200DD74-0001



Tall storage unit with open
base & 2 doors,
30" x 24½" x 74½"
200DD74-0002



Tall storage unit with open
base & 1 door,
30" x 24½" x 74½"
200DD74-0003

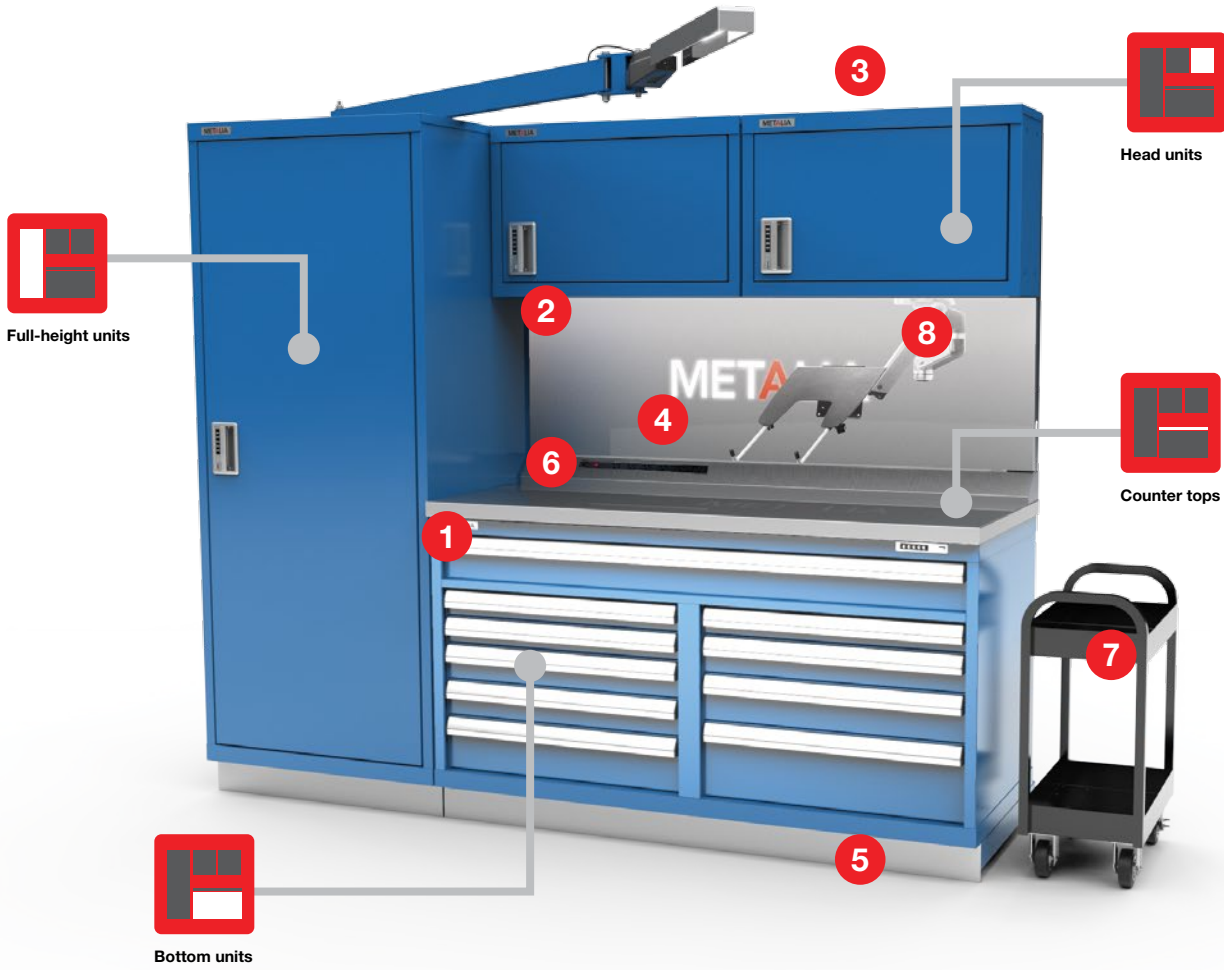

Accessories

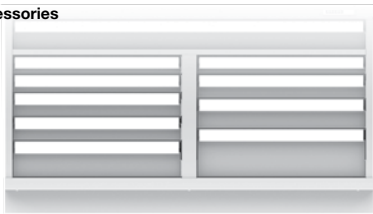

- 1 LED lighting for cabinets**
 30" 221DZ00-0001
 60" 221MZ00-0001
 90" 221RZ00-0001



- 2 LED lighting for Head units**
 24" 220CZ00-0001



- 3 LED lighting arm**
 222RZ04-0001



- 4 Back Panel**
 15" 236AZ21-0001
 30" 236DZ21-0001



- Stainless steel back panel with logo**
 30" 236DZ21-0002
 60" 236MZ21-0002



AVAILABLE WITH YOUR LOGO!
 Ask us about it!



- 5 Stainless steel kickplate**
 15" 261AZ00-0001
 30" 261DZ00-0001
 60" 261MZ00-0001

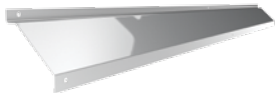

- 6 Back stopper, stainless steel**
 15" x 4" x 4" 237AZ04-0001
 30" x 4" x 4" 237DZ04-0001

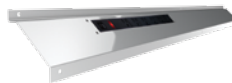

- Back stopper with power bar (6 outlets)**
 30" x 4" x 4" (use with uprights) 237DZ04-0002
 30" x 4" x 4" (use without uprights) 237DZ04-0011
 60" x 4" x 4" (use without uprights) 237MZ04-0011
 90" x 4" x 4" (use without uprights) 237RZ04-0011



- 7 Mobile cart**
 13" x 23" x 31" 230ZD31-0001



- 8 Laptop support arm plate**
 265ZZ00-0002
 265ZZ00-0003



MS

MODULAR CABINETS
& DRAWERS



WRS

WORKSTATIONS



MRS

TOOLBOXES



METALIA®

Montreal, QC • Atlanta, GA • Mexico City, MX

Toll free: 1 844-METALIA

metalia.com

© 2016 Metalia® All rights reserved

MTL15001
v. 2016-22e